

## Field Record of Previous Burials

*These sheets to be used on the grounds to secure data which will be copied permanently in Cemetery Lot Record.*

NOTE: Each small square represents a square foot of lot surface. For convenience each tenth foot is indicated by a heavy line. To make a record of previous burials, draw a diagram, with pencil, of each lot, beginning with Lot No. 1, and use a separate sheet for each lot. This can be done in the office from the plat and the owner's name and other data as to ownership secured from deed record. These blanks will then be taken to the cemetery and a record will be made from the lots, of the names of those buried and location of grave on lot. A number corresponding to name must be placed on plat to identify grave.

Description Owned Southview, Block 8, W 1/2 Lot No. 23, \_\_\_\_\_ Ft.  
Addition, Sub-division or Section Part of Lot Dimensions

Name of Owner Currie Address \_\_\_\_\_ Date Sold 2016

Remarks: Concrete Vault Price, \$ \_\_\_\_\_

41

INDICATE DIRECTION BY N. S. E. OR W.

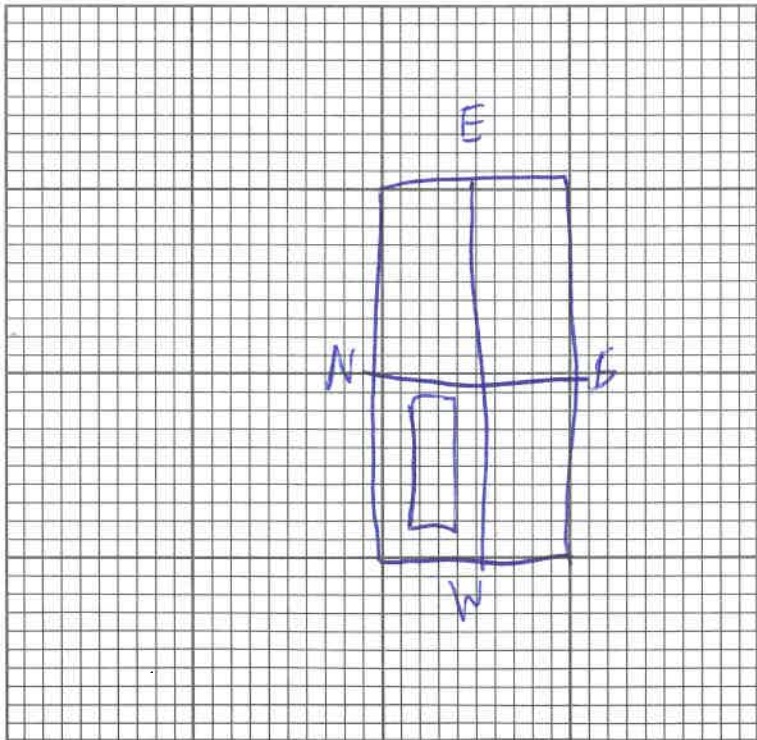

Grave No.	FULL NAME OF DECEASED	REMARKS
1	Donna Currie	
2		
3		2' from N lot line
4		in N 1/2 to center of grave
5		
6		2' 6" from W lot line
7		in W 1/2 to edge of grave
8		
9		
10		
11	Nishna	
12	12 - 21 - 20	

# BURIAL REPORT

From Sexton to Secretary of Cemetery  
(TO BE RECORDED IN CEMETERY RECORD)

Burial or Permit No. ....

1. Place of Death Page Shenandoah Residence  
(County) (Township or City) (Facility)
2. Name: DORIVA Low FERN CURRIE
3. Sex: Female 4. Color or Race: caucasian
5. Single, Married, Widowed or Divorced: Divorced
6. Date of Birth: 07-01-1939 7. Age: 81 Years \_\_\_\_\_ Months \_\_\_\_\_ Days
8. Occupation: Bank Teller Retired
9. Birthplace (State or County): Page Iowa
10. Name of Father: Jesse W. Stanbough
11. Birthplace of Father: N/A
12. Maiden Name of Mother: FERN E. SWANSON
13. Birthplace of Mother: NA
14. Informant: Kevin Currie 15. Address: 5430 CROW WING HEIGHTS CT., BRAINARD MN
16. Date of Death: 12-12-2020

- Name of Doctor (or Coroner or Health Officer): DR. THEO BARLEY  
Address: Clarinda Regional Hosp. 200 ESSIE DAVIDSON DR. CLARINDA, IA 51632  
Place of Burial or Removal: Rose Hill cemetery Date of Burial: 12-21-2020
19. Undertaker: John P. Liece Address: 405 W. THOMAS AVE. SHENANDOAH, IA

## BURIAL REPORT

No. 8565

Name DORIVA Low FERN CURRIE

Burial Date 12-21-2020

Date of Death 12-12-2020

450.00